

# SLC ultra low jitter Clock Synthesizer

2 MHz to 7 GHz

Datasheet

## NOISE XT

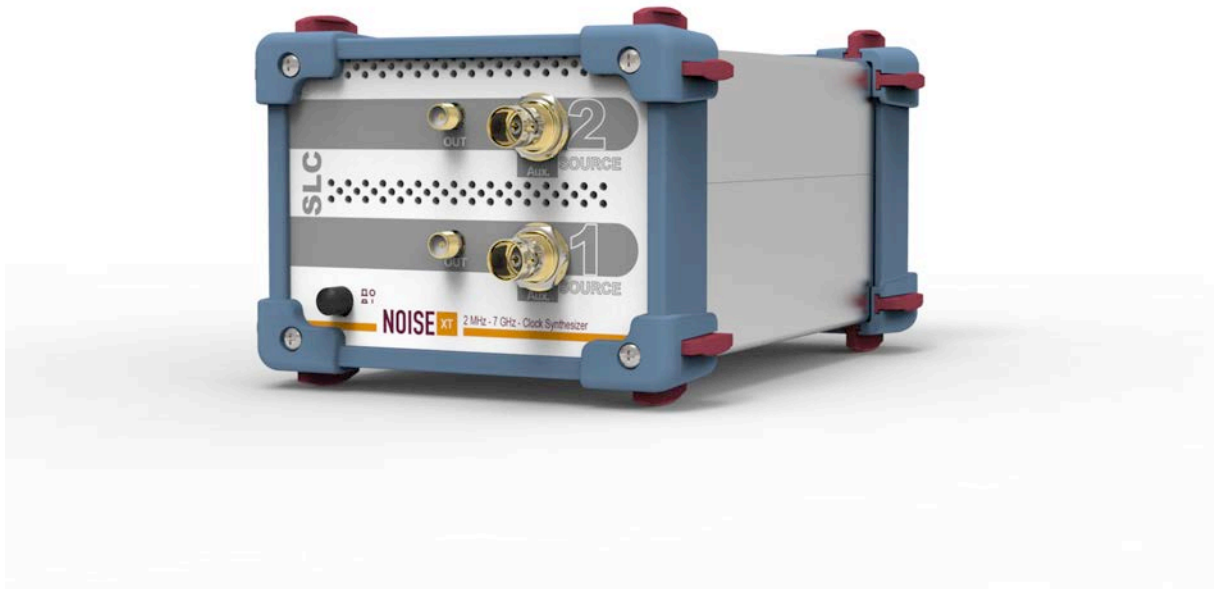

The SLC is a very affordable single or dual clock 7 GHz synthesizer that exhibits outstanding phase noise and jitter performance in a very small package.

With  $-170$  dBc/Hz phase noise floor at 10 MHz, the SLC is the lowest phase noise compact clock synthesizer of the industry that can help you challenge tomorrow's requirements for high speed, high bandwidth Software Defined Radio applications (SDR) and low phase noise PLL and DDS synthesis.

Its high power output is ideal to drive mixers' LO inputs or high-speed digital clocks. Its very low jitter profile makes ADC and DAC testing more accurate. This source is often cleaner than a crystal oscillator and can offer a high SNR, up to 135 dB.

USB control helps you seamlessly integrate this tool in your test project or clock distribution architecture. Both synthesizers can be controlled completely independently and do not share any common reference frequencies. However, when coherent signals are required, they can be locked to each other with the help of their 10 MHz reference signals.

Optional ultra low phase noise OCVCXO allows the synthesizers to reach their best specification and if this is not enough, the external 10 MHz reference input will extend its long term frequency stability (Allan variance) to the one of atomic clocks.

Specifications below describe the RF inputs and Outputs for each synthesizer. When 2 synthesizers are present, there are two sets of inputs and outputs.

## RF Output Specifications

Description	Specification
Output Frequency	2 MHz to 7 GHz
Frequency Resolution	0.001 Hz
Frequency Switching time (list mode)	< 1 ms or < 150 us (option)
Frequency Dwell time	2 ms to 20,000 ms
Output Level	-30 dBm to +13 dBm (to +17 dBm in 4 MHz-4 GHz)
Level Resolution	0.5 dB
Non-Harmonic spurious	-70 dBc above 1 kHz offset (-76dBc typ)
Modulation	DC coupled FM (8ppm/V VCXO, 0.6ppm/V OCVCXO option, 1kHz BW max)
Output connector	SMA female, 50 Ohms

## Typical Output Power Level

Below is the maximum RF output power level for the whole band. The SLC is capable of +18 dBm in most of its band and drive power demanding applications.

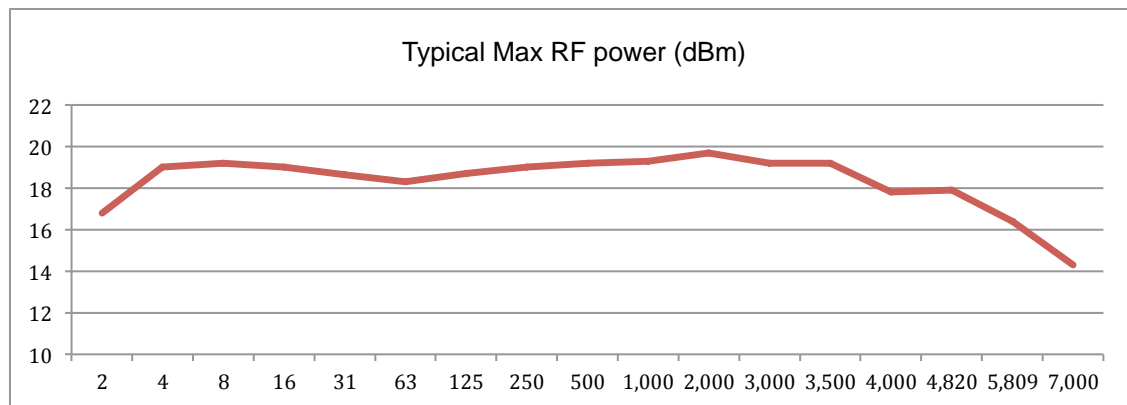

## Phase Noise performance

Typical Phase Noise with standard phase noise installed (VCXO).

dBc/Hz vs offset (Hz)	100	1k	10k	100k	1M	Floor
10 MHz	-130	-160	-168	-170	-170	-170
100 MHz	-110	-141	-154	-156	-158	-164
1 GHz	-94	-123	-134	-137	-142	-164
2 GHz	-88	-117	-128	-126	-129	-160
4 GHz	-82	-111	-123	-125	-130	-160
7 GHz	-76	-105	-117	-119	-121	-155

please add +5dB for guaranteed performance

Typical Phase Noise with ultra low phase noise option installed (OCVCXO).

dBc/Hz vs offset (Hz)	100	1k	10k	100k	1M	Floor
10 MHz	-150	-160	-168	-171	-175	-175
100 MHz	-133	-147	-155	-157	-158	-169
1 GHz	-113	-127	-136	-137	-142	-164
2 GHz	-108	-121	-130	-131	-134	-160
4 GHz	-102	-115	-124	-125	-129	-164
7 GHz	-97	-110	-119	-121	-122	-157

please add +5dB for guaranteed performance

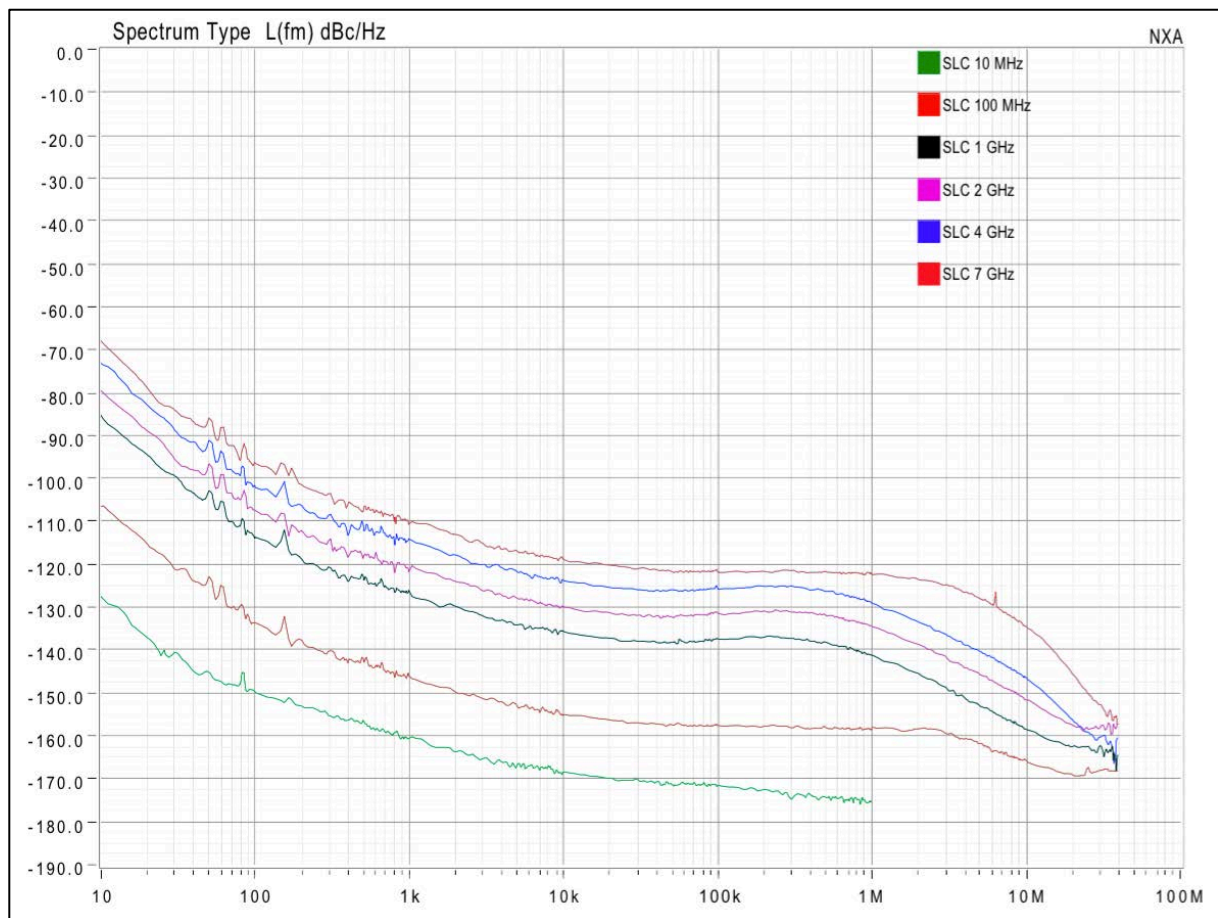

Typical Phase Noise plots at various frequencies with ultra low phase noise OCVXO option

## Typical Residual FM Computation

The Residual FM can be computed from the Phase Noise plots with various un-weighted bandwidth.

RMS FM (Hz) vs carrier (MHz)	10	100	1000	2000	4000
50 - 3k Hz	0.001	0.007	0.061	0.094	0.19
300 - 3.4k Hz	0.001	0.008	0.066	0.107	0.19
20 - 15k Hz	0.005	0.032	0.303	0.595	1.03

## Typical RMS Jitter Computation

Based on the spectral purity of the Clock, the Jitter can be extracted

jitter RMS (fs) vs carrier (MHz)	10	100	1000	2000	4000
10k-1M Hz	67	32	44	54	27
10k-10M Hz		66	81	78	33
10k-40M Hz		98	87	83	35
10k-100M Hz			89	84	36

For some specific clock frequencies, the following table is obtained

jitter RMS (fs) vs carrier	155 MHz	622 MHz	2.488 GHz
100 - 1.5M Hz	40		
1k - 5M Hz		74	
5k - 15M Hz			70

## Signal to Noise Ratio (SNR) when used as an ADC clock

The SNR can be computed for various analog sampled input frequencies (also called IF) and for various jitter integration bandwidths (depending on the application useful bandwidth)

For most common cases ( $F_{clk} / F_{IF}$ ), the SLC clock generator will achieve the following performance.

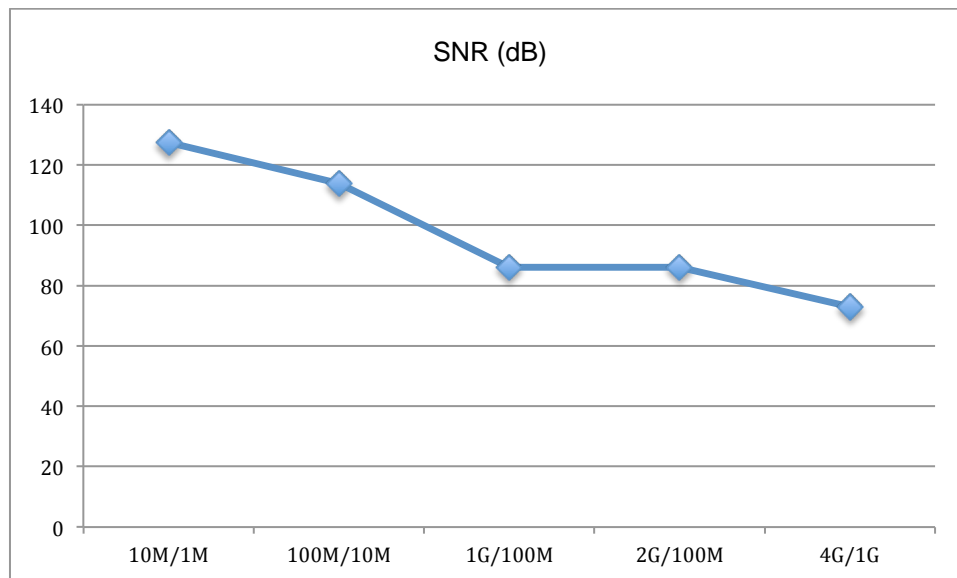

However, a more detailed Signal to Noise Ratio can be computed as shown in the tables below.

SNR in dB for 80 MHz total bandwidth (10k-40MHz Jitter integration bandwidth)

SNR dB vs Clock (MHz)	10	100	1000	2000	4000
IF= 1 MHz		122	125	126	133
IF= 10 MHz		102	105	106	113
IF= 100 MHz		82	85	86	93
IF= 1 GHz		62	65	66	73

SNR in dB for 20 MHz total bandwidth (10k-10MHz Jitter integration bandwidth)

SNR dB vs Clock (MHz)	10	100	1000	2000	4000
IF= 1 MHz		128	126	126	134
IF= 10 MHz		108	106	106	114
IF= 100 MHz		88	86	86	94
IF= 1 GHz		68	66	66	74

SNR in dB for 2 MHz total bandwidth (10k-1MHz Jitter integration bandwidth)

SNR dB vs Clock (MHz)	10	100	1000	2000	4000
IF= 1 MHz	128	134	131	129	135
IF= 10 MHz	108	114	111	109	115
IF= 100 MHz	88	94	91	89	95
IF= 1 GHz	68	74	71	69	75

## Reference input

Description	Specification
Frequency	10 MHz
Level	+5 dBm (+/- 5 dB)
Loop Bandwidth	10 Hz
Connector	BNC (female), 50 ohms

## Reference output

Description	Specification
Frequency	10 MHz
Level	+7 dBm (+/- 3 dB)
Connector	BNC (female), 50 ohms

## EFC / DC-FM Control

Description	Specification
Voltage	0 to + 5V standard, 0 to +10V with OCVCXO fitted
Impedance	2.2 kOhms
Bandwidth	1 kHz max

## Programming features

Description	Supplemental information
Modes	CW and Sweep, List through programming
Interface	National Instruments LabView® examples and driver for USB Windows® OS compatible Graphical User Interface for Windows®

## General Information

The connections described below are shared between the synthesizers. Only one set is present, regardless of the number of synthesizers present in the SLC.

### Rear panel information

Description	Supplemental information
USB	1 ports (USB 2.0)
DC power	+10 to +24 V input port
Power	15W per synthesizer
FAN	Intake

### Synthesizer environment and dimensions

Description	Supplemental information
Operating environment	
Temperature	+10 degC to +40 degC
Humidity	RH 20% to 80% at wet bulb temp.<29 degC (non-condensing)
Altitude	0 to +2 000 m
Non-operating storage environment	
Temperature	-10 degC to +60 degC
Humidity	RH 20% to 90% at wet bulb temp.<40 degC (non-condensing)
Altitude	-427 to +4 810 m
Vibration	0.5 G maximum, 5 Hz to 500 Hz
Instrument dimensions	See figure below
Weight (NET)	< 1 kg for dual configuration

### Dimensions information

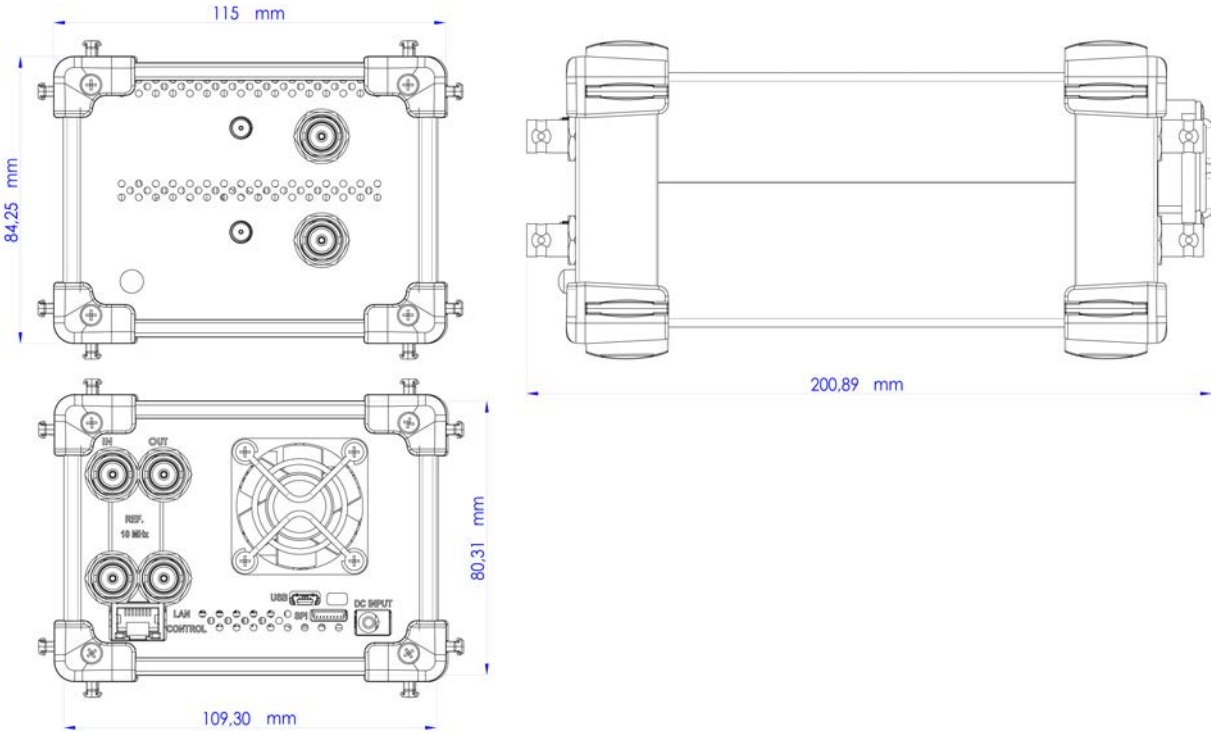

### Ordering Information

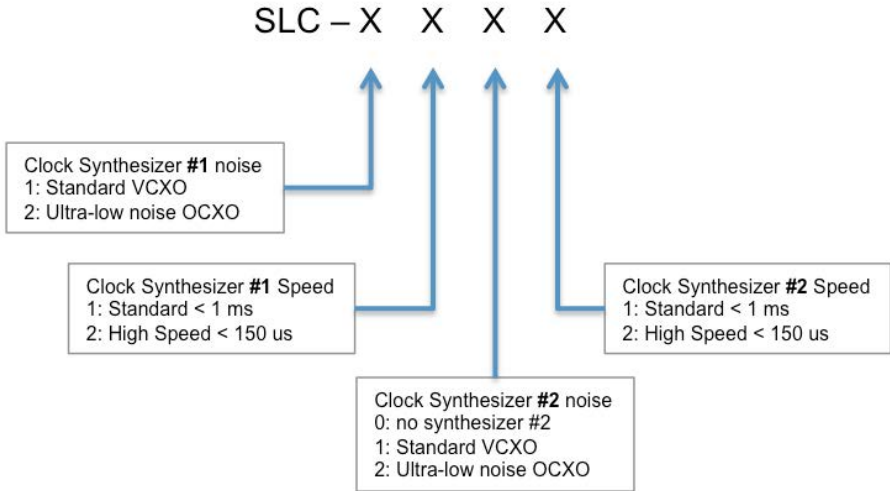

Noise eXtended Technologies  
 An ISO 9001 : 2008 certified company

