

**Paper No. 2095
Index Cat. No. 6**

The Seven Secrets of Accurate Mass Properties Measurement

by

**Richard Boynton, President
Space Electronics, Inc., Berlin, CT 06037**

**For Presentation at the
51st Annual Conference
of the
Society of Allied Weight Engineers, Inc.
Hartford, Connecticut, 18-20 May 1992**

See Space Electronics' Products & Measurement Services

**Weight & Center of Gravity | Moment of Inertia | Moment Weight | Dynamic
Balances | Gimbal Balances | Inertial Roll Decay | Igniter Circuit Testers**

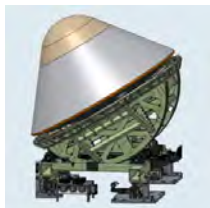

+1 860 829 0001 sales@space-electronics.com, 81 Fuller Way, Berlin, CT 06037 USA
www.space-electronics.com

ABOUT THE AUTHOR

Richard Boynton is President of Space Electronics, Inc., Berlin, Connecticut, a company he founded in 1959. Space Electronics, Inc. manufactures instruments to measure moment of inertia, center of gravity, and product of inertia. Mr. Boynton has designed many of the mass properties measuring instruments manufactured by Space Electronics. He holds a B.E. degree in Electrical Engineering from Yale University and has completed graduate studies in Mechanical Engineering at Yale and MIT. He is the author or co-author of 72 papers, including 35 papers presented at SAWE International Conferences and 3 papers presented at Regional Conferences. Three of Mr. Boynton's papers have won the L. R. "Mike" Hackney Award for Best Technical Paper at the International Conference of the SAWE. He is the author of the SAWE Recommended Practice for Standard Coordinate Systems for Reporting the Mass Properties of Flight Vehicles. Mr. Boynton has been a member of SAWE for over 30 years and is currently Director of the Boston Chapter. In 1992 he was elected a Fellow and in 1998 was elected an Honorary Fellow of the SAWE. Mr. Boynton is also a member of the AIAA and the Society of Automotive Engineers, where he serves on the Balancing Subcommittee (which is currently involved with setting standards for jet engine balancing).

Mr. Boynton is a former professional folksinger. In addition, he is an artist, specializing in pen and ink drawing. He recently illustrated a book of poems entitled "A Web of Longing and Desire" (published by Lamentation Mountain Press).

Permission to publish this paper, in full or in part, with full credit to author may be obtained by request to:

Society of Allied Weight Engineers, Inc.

P.O. Box 60024, Terminal Annex

Los Angeles, CA 90060

The Society is not responsible for statements or opinions in papers or discussions at the meeting.

Abstract If you have a mass properties instrument which has an accuracy of 0.1%, how accurately can you measure the mass properties of your payload? Some people think that the answer is 0.1%. In fact, the instrument is usually the least important factor in determining measurement accuracy. There are a number of fatal mistakes which you can make that will produce errors that are 10 or 100 times as large as the inaccuracy of the instrument. Over the years I have concluded that there are seven secrets for accurate mass properties measurement. These are:

Secret Number 1 - The payload must have precisely defined measurement axes. Both your calculated and your measured data are only as good as your ability to define the axes of the payload.

Secret Number 2 - The fixture must hold the payload so its measurement axes are precisely located relative to the instrument. Fixturing error is the number one source of measurement error in most mass properties measurements.

Secret Number 3 - You must follow the correct measurement procedure. The four most common procedural errors are:

A. Tare measurement is made with mounting bolts left out or clamp set in a different position than when the measurement was made.

B. Payload is not in flight configuration (arming switch must be set, shipping clamps must be removed, protective covers must be removed, tanks must be filled with fuel).

C. Fixture unbalance is too large. This must be smaller than the desired balance. Otherwise you will be subtracting two large numbers. A small error in either will result in a large error in the difference. Also, the machine will have to be set on a low sensitivity range.

D. Payload is fixtured so its CG is too far from balancing machine axis. (This is similar to the problem described above). This also results in overturning moment stiffness errors. Since no balancing machine is infinitely stiff to an overturning moment due to CG offset, all payloads lean toward their CG. To get the most accurate measurements, reposition the payload so its CG is on center and remeasure.

Secret Number 4 - You must eliminate external influences (drafts, temperature changes, vibration, air mass).

Secret Number 5 - The payload must weigh more than 2% of the capacity of the mass properties machine. Instrument accuracy is generally a function of payload weight or moment of inertia. If you try to measure a small object on a large machine, then it is like trying to weigh yourself on a 20,000 pound truck scale; the answer gets lost in the background noise.

Secret Number 6 - You must use an accurate instrument. Sensitivity and repeatability are not the same as accuracy. If your calibration standard is in error, then all of your measurements will also be in error. If the payload leans away from the centerline of the instrument, this will result in a large measurement error.

Secret Number 7 - You must define your symbols and polarities. Define which axis is X, which axis is Y, etc. Your X may be someone else's Y. Even within one company, one department may call the roll axis X and another department may call it Y. If you submit the data without defining the axes, each group will use its own set of coordinates in interpreting the data.

Secret Number 1. The payload must have precisely defined measurement axes. The mass properties of an object cannot be separated from the axes used as a reference. In fact any object has an infinite number of values for CG, moment of inertia, and product of inertia, depending on where you choose to assign the axes. If the object is a smooth ground cylinder, then it is obvious where the axes are located. However, on real parts,

flat surfaces are not perfectly flat;

round surfaces are not perfectly round;

concentric surfaces are not exactly on the same center;

perpendicular surfaces are not exactly perpendicular;

some surfaces are soft (cork, thick paint).

STEP 1 = Calculate the required mechanical dimensional tolerances necessary in order to be 10 times better than the accuracy specification for mass properties. For example, if CG accuracy required is 0.005 inch, then you must know the location of the reference axes to an accuracy better than 0.0005 inch. Tolerances for product of inertia are trickier to calculate. The best approach is to first calculate the axis tilt corresponding to the POI tolerance, and then relate this to TIR runout of two reference diameters.

STEP 2 = Do a dimensional inspection of the payload. If the payload outer surface is less accurate than the tolerances calculated in step 1, then you are in trouble.

NOTE: Space Electronics provides a measurement service to small companies who do not have the funds to purchase a mass properties instrument. For at least 30% of the measurements we are asked to do, we discover that the dimensional tolerances of the object are not tight enough to permit the mass properties accuracy required!

QUESTION: If the dimensional tolerances are not sufficient to achieve the accuracy required, what do you do?

ANSWER: You must know why the specification was important, and then you can devise some means of accomplishing the real goal. For example, the real reason for controlling CG may be to put the CG on the center of thrust. If you can locate the CG relative to the centerline of the nozzle, then you can accomplish this goal even if the outer surface of the vehicle is made of soft cork. This topic is discussed in some detail in the SAWE paper number 2101 entitled "An Expanded Role for the Mass Properties Engineer" by Richard Boynton, President, Space Electronics, Inc.

QUESTION: What do you do if the mass properties measurement test plan requires you to measure CG relative to a nebulous datum, when you know the purpose of this measurement is to align the CG with the center of thrust?

ANSWER:

1. Do the right thing. Measure the CG relative to the center of thrust and make the proper correction.
2. Fudge the data to keep the inspector happy (i.e. after you do the right thing, find a way of expressing the data so you pass the test).
3. Try to get the test changed so you won't have to play games in the future.

If you have an influence in the early stages of a design, maybe you can convince the project engineer to add two precision datum rings to the payload. This will give you a reliable interface for your fixture and will also give you something to measure to determine if the payload is located correctly in the fixture. Engineers who align the guidance system will find these rings invaluable. Thruster nozzles can be located relative to these rings.

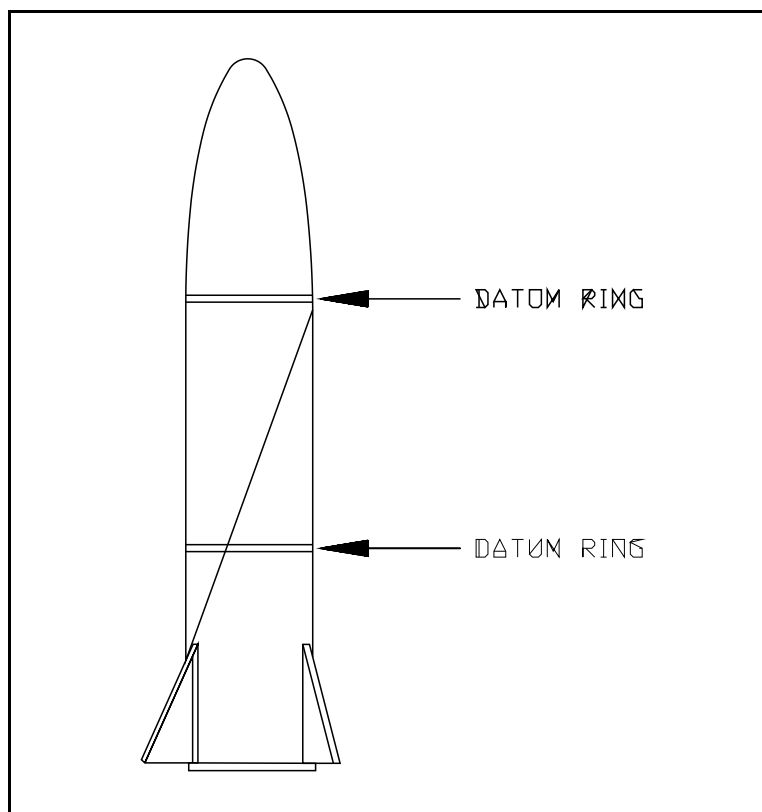

Secret Number 2. The fixture must hold the payload so its measurement axes are precisely located relative to the instrument. Fixturing error is the biggest error in most measurements. Years ago a customer called us after receiving a mass properties instrument and said "There's something wrong with the instrument; I can get any answer I want by just moving the payload to a new position on the mounting plate of the instrument." We all got a good laugh at Space Electronics, and frankly we thought the customer was a real moron. Since then we have come to realize that many people do not fully realize the importance of accurate fixturing.

POI: Even the smallest tilt is very significant; payloads should be dial indicated whenever possible. Do not rely on the fit in a fixture to establish position.

CG: A 0.001 inch fixturing error translates to a 0.001 inch measurement error. It is very difficult to get this kind of accuracy unless the payload has a precision outer surface.

MOI: Fixturing accuracy is not critical except if the payload is tall and thin. The reason for this is that the error is proportional to the square of the ratio of radius of gyration ("k") and fixture offset error ("d"). Generally the fixturing error is less than 1% of the radius of gyration, so the resulting error will be less than 0.01%. This relationship is derived below, using the well-known formula for translations of axes.

Using a Precision Dummy Payload One very convincing method to verify fixture accuracy is to construct a precision test weight with known mass properties which interfaces with the fixture in the same way as the real payload. For example, this weight might be a simple cylinder of constant diameter. If the mass of a solid cylinder would be too large, but you need a large diameter to interface with the fixture, you can use a small diameter solid cylinder with a larger diameter disc attached to each end.

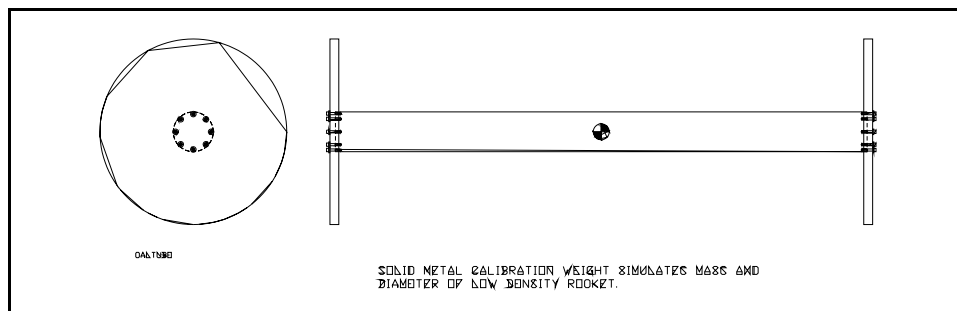

Work reversal method (only works for symmetrical objects) Errors in fixture position relative to the measurement axis of the instrument can be eliminated by turning the object 180° in the fixture and remeasuring unbalance. The unbalance magnitude should stay the same; angle should change by 180°. If you average the results and divide by two, then fixture position error is washed out.

Note: this method eliminates fixture position error, but does not eliminate errors due to poor fit in the fixture.

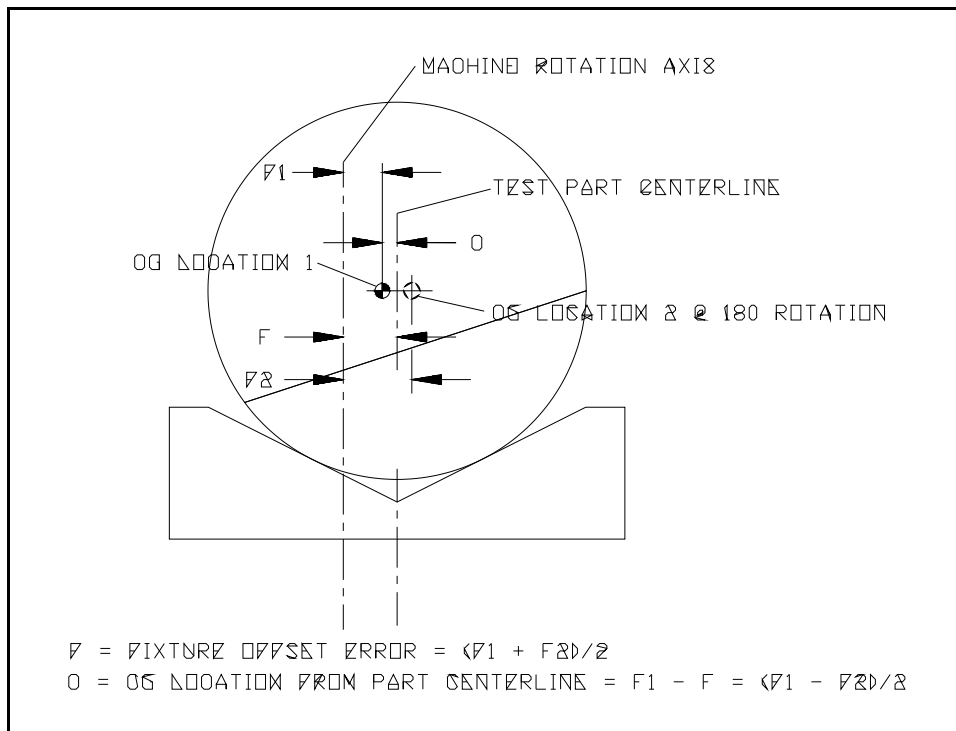

Work Reversal Method Eliminates Fixture Error

Secret Number 3. You must follow the correct measurement procedure.

This means you must have a written procedure! Write it as a step-by-step guide. Don't say "Measure tare". Instead say "Loosen the clamp screw, remove the payload from the fixture and then tighten the clamp screw so it is in exactly the same position as when the payload was in place.....etc".

Set limits in the procedure. Don't say "Center payload in fixture". Say "Center payload in fixture so upper and lower rings run out less than 0.001 TIR".

Be very careful how to describe how the payload fits in the fixture. This is particularly important

when the payload can be accidentally put in backwards. Something which may be obvious to you will not necessarily be obvious to someone else.

The procedure should caution the technician about burrs, dirt between payload and fixture, misalignment.

The procedure must be specific for the payload being measured (other payloads will have to be positioned differently, even if the same fixture is being used).

The four most common procedural errors:

1. **Tare measurement is made with mounting bolts left out** or clamp set in a different position than when the measurement was made.
2. **Payload is not in flight configuration** (arming switch must be set, shipping clamps must be removed, protective covers must be removed, tanks must be filled with fuel).
3. **Fixture unbalance is too large.** This must be smaller than the desired balance. Otherwise you will be subtracting two large numbers. A small error is either will result in a large error in the difference. Also, the machine will have to be set on a low sensitivity range.
4. **Payload is fixtured so its CG is too far from balancing machine axis.** (This is similar to the problem described above). This also results in overturning moment stiffness errors. Since no balancing machine is infinitely stiff to an overturning moment due to CG offset, all payloads lean toward their CG. To get the most accurate measurements, reposition the payload so its CG is on center and remeasure.

Secret Number 4. Eliminate external influences (drafts, temperature changes, vibration, air mass). Any external force will degrade the accuracy of a mass properties machine. However, each kind of measurement is more sensitive to a certain kind of external influence.

CG is most sensitive to temperature changes. Generally we recommend that the short term changes be less than 1° F per 15 minutes. This does not require an expensive air conditioner. A simple shroud will generally do the trick. Make certain the output of the heating/air conditioning system is not near the instrument.

MOI is most sensitive to drafts. This will be immediately obvious, since the drafts will cause the time period to show random variations. In the proper environment, time period reading should be repeatable within three parts in 100,000.

POI is most sensitive to ground vibration. Static CG machines filter out vibration forces, since the average of these forces is zero. However, a spin balance machine measures the

sinusoidal vibration at the bearing mounts, so the force transducers have to be able to detect vibration. Tracking filters in the machine eliminate vibration whose frequency does not coincide with the rotational speed, but any external signal whose frequency is close to the rotational speed of the machine will cause an error in measurement. Do not locate a spin balance machine near air compressors, "shakers" used in vibration analysis and testing, or lift truck traffic.

Effect of air mass For large lightweight payloads, the measured mass properties are often significantly different from the calculated values. In particular, measured moment of inertia can be 10% to 20% larger than calculated. The reason for this is that air has significant mass and alters the mass properties in two ways:

Air trapped **inside** the payload will increase its mass by an amount equal to the unoccupied volume in the payload times the density of air (0.0754 pounds per cubic foot). For example, the air trapped in a 6 foot diameter satellite might weigh approximately 4 lbs. We call this the entrapped air effect.

Air dragged or pushed along by any protrusions on the outer surface of the payload can dramatically increase moment of inertia. For example, the roll moment of inertia of an aircraft flying in air is much larger than the roll MOI of the aircraft in a vacuum. We call this the entrained air effect.

How you handle this difference depends on whether the payload operates in the vacuum of space or in air. If the payload flies in a vacuum, then measured values must be decreased to eliminate the effect of air mass. The best way of doing this is to make a second measurement in helium and then extrapolate the value in vacuum (see SAWE paper No. 2024 by Boynton and Wiener). Calculated values remain unchanged.

If the payload flies in air, then measured values remain unchanged and represent the true mass properties. Calculated values should be changed to reflect the effect of air mass.

Secret Number 5. Buy an accurate instrument.

The instrument must be at least 5 times more accurate than the required tolerance on mass properties.

Accuracy versus sensitivity A CG sensitivity of 0.001 inch tells you that if you move the payload by 0.001 inch, the machine will be able to detect that you made this change. A CG accuracy of 1% means that if you measure a CG offset of 0.100 inch, then the true offset is between 0.099" and 0.101". There is a big difference between these two specifications.

Machine measurement axis Machines that use rotating mounting plates have a clearly defined axis (the center of rotation). The payload can be very accurately aligned to this axis by using a dial indicator. Load cell tables may be sensitive to CG change, but there is no well defined zero or measurement axis. Machines with gas bearing rotary tables are the most accurate.

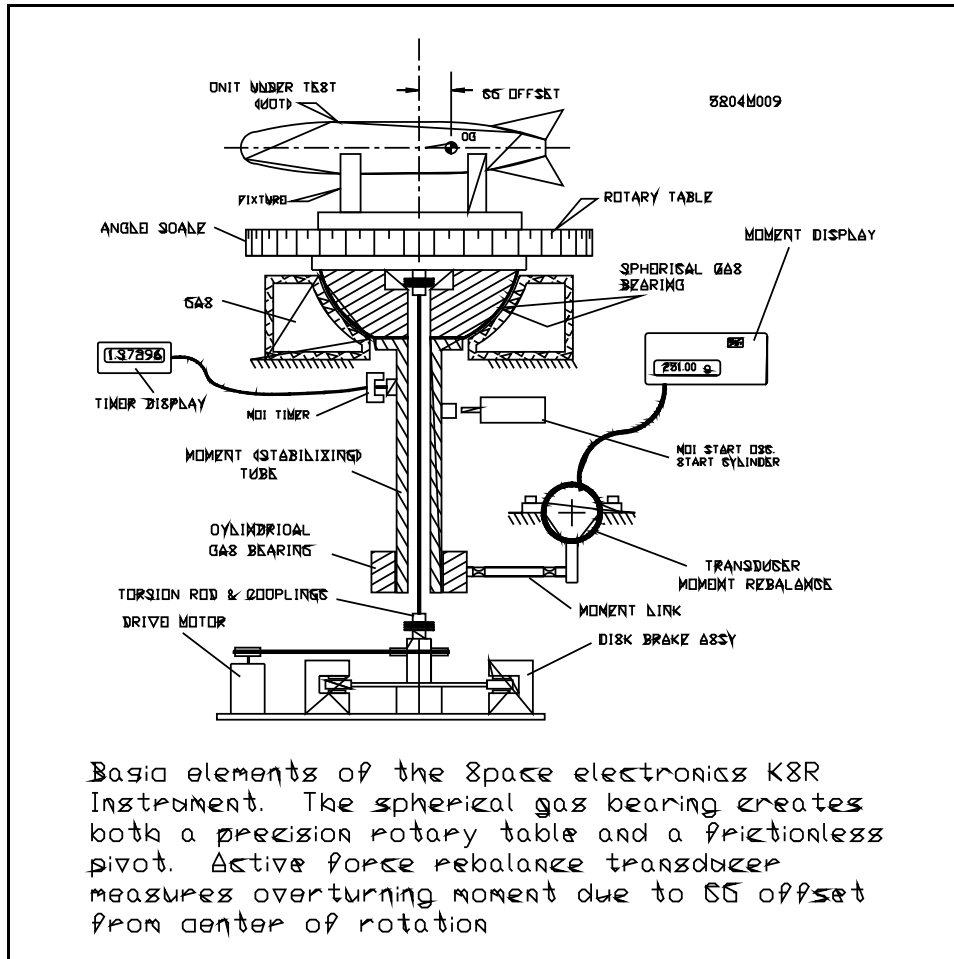

Calibration weight errors Since the "scale factor" of a mass properties instrument is determined by measuring a known calibration weight, an error in the calibration magnitude will result in consistent errors in all measurements. Calibration weights should be precision machined and be traceable to NIST.

Stiffness to overturning moment A CG instrument may be accurate when measuring low profile payloads, but the accuracy can degrade very rapidly if the payload is tall and thin. The reason for this is the displacement of the payload due to lean. This problem is particularly evident on three-load-cell type CG instruments which hang the test table from aircraft cable. If the payload CG is displaced from the center of the machine, then there

is a moment created. This moment causes the table to lean toward the CG, increasing the apparent CG offset. The higher the CG from the surface of the table, the more pronounced this effect will be. Instruments which use rebalance technology (such as the Space Electronics KSR series) do not exhibit this type of error because the closed loop feedback keeps the table level independent of CG offset.

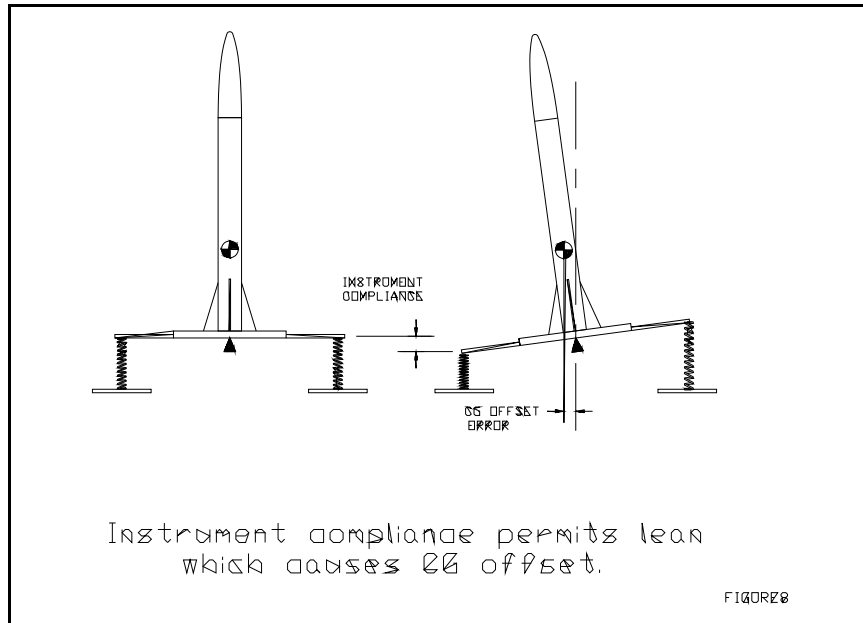

INSTRUMENT ACCURACY TESTS:

1. Repeatability of instrument (Leave object in fixture and remeasure.)
2. Repeatability of fixture (Remove object from fixture and replace; then remeasure.)
3. Accuracy of instrument (Add known unbalance and see if machine gives correct change in total unbalance.)

Secret Number 6. Payload should usually weigh at least 2% of maximum capacity of machine. You know you shouldn't measure your weight on a 20,000 lb truck scale. The same principal applies to balancing a 4 pound payload on a 1000 pound spin balance machine.

MOI accuracy is reduced when the MOI of a payload is smaller than the tare MOI of the instrument. For example, if a payload has a MOI of 10 lb-in², and the instrument has a tare MOI of 10,000 lb-in², then a 0.1% change in tare due to an ambient temperature change will result in a 100% error in the measured MOI of the payload.

CG accuracy is generally expressed in terms of moment accuracy. If a 10,000 lb-in full scale CG instrument has a moment accuracy of 1 lb-inch, then this will result in a CG error of $1/10,000 = 0.0001$ inch for the maximum payload weight of 10,000 pounds. If the payload weighs 1000 pounds, then the same instrument will give an error of $1/1000 = 0.001$ inch. If the payload weighs 100 pounds, then the error will be 0.010 inch, and so on.

POI accuracy is generally expressed in terms of minimum detectable unbalance in lb-in². The bigger the machine, the larger will be this minimum detectable POI. The reason for this increase is that the larger machine must use a heavy rotating spindle. Minor alterations in the rotational center of this spindle will cause a change in the residual unbalance of the machine. Furthermore, the heavy spindle has a larger change in bearing force for a given displacement magnitude of ground vibration. If the machine spindle weighs 1000 pounds and you are trying to balance a payload weighing only 1 pound, then ground vibration of only a few millionths of an inch may affect your accuracy.

Secret Number 7. You must define your symbols and polarities. Define which axis is X, which axis is Y, etc. Your X may be someone else's Y. Even within one company, one department may call the roll axis X and another department may call it Y. If you submit the data without defining the axes, each group will use its own set of coordinates in interpreting the data. These problems can be minimized by adopting a standard coordinate system for mass properties measurement. See my 1991 SAWE paper entitled "Proposed SAWE Standard Coordinate System". We are planning to discuss this issue at the 1992 SAWE conference and adopt a standard. Hopefully, by the time you read this paper, such a standard will be in place.

Moment of inertia can only be positive, so there is never any confusion regarding sign. However, you should determine whether this magnitude should be expressed through the geometric centerline of the vehicle or through its CG about an axis parallel to the geometric centerline or rotated so the data is through the principal axes. In most cases, there will not be a big difference in these three magnitudes. This can lead to confusion, since it will not be immediately obvious that the wrong data is being presented.

Center of gravity can be positive or negative. You should determine whether your positive axis agrees with the definition of axes used by the recipient of your data. Furthermore, CG distance can be expressed along a coordinate system defined by the geometry of the vehicle or along the principal axes.

Product of inertia can also be positive or negative. Since this quantity is derived by multiplying the incremental masses by two different distances, the POI sign is even more prone to error than the sign of the CG data. I frequently hear the comment: "I can calculate POI, but I never get the sign right". What usually happens is not that the sign is wrong, but that the mass properties engineer and the recipient of his data are using different coordinate systems.

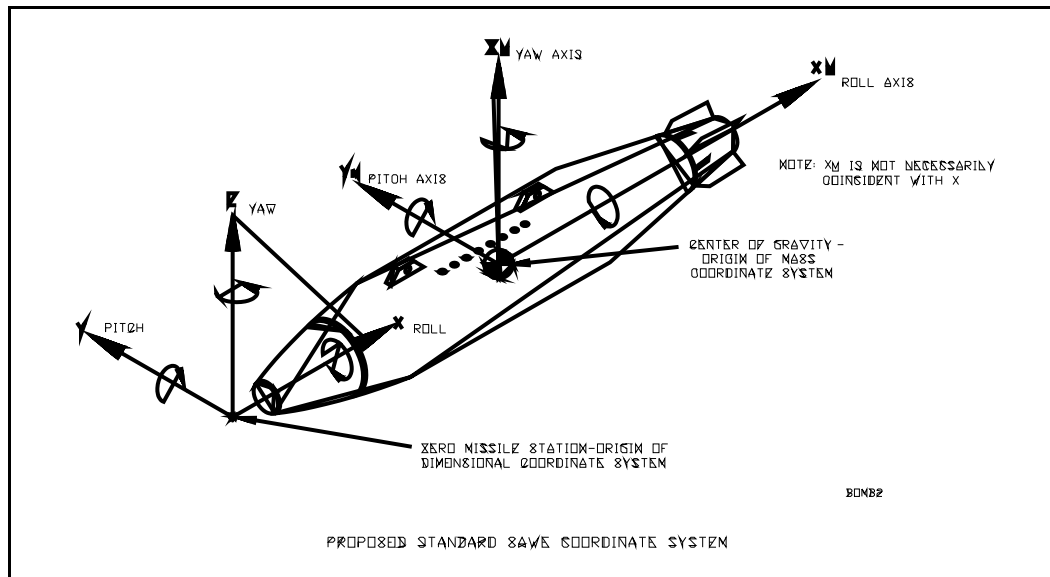

About vs along Moment of inertia is expressed about an axis. CG can be a distance along an axis, or a moment about an axis (CG along X corresponds to the CG moment about Y). POI is relative to two axes (or it can be a tilt angle in a plane defined by two axes).

Testing the Mass Properties Data for Reasonableness Without knowing any of the details of a particular payload, it is possible to check the measured data to see if it falls within some basic guidelines:

CG No matter how the mass is distributed, the CG of an object must be within the outline of the object. If the object is a thin rocket whose nose is 100 inches from the aft end, then the CG certainly must be less than 100 inches from this aft end. It's likely that the CG will be between 33 inches and 66 inches from the aft end. The radial CG will normally be close to center (within 0.100 inch).

MOI The MOI about one axis cannot be greater than the sum of the MOI's about the other two orthogonal axes. A proof of this handy test is found on page 12 of George Strom's SAWE paper No. 1946 entitled "Matrix Methods for Mass Properties".

The radius of gyration of the payload must be less than the longest dimension at right angles to the axis. For example, if the MOI about the roll axis of a 100 pound missile is measured to be 10,000 lb-in², then the corresponding radius of gyration is the square root of 10,000/100 = 10 inches. If the radius of the surface of the missile is 5 inches, then there is something wrong with the measurement. If the missile were of constant density, then you would expect the radius of gyration to be about 70% of the radius, so in this case the true radius of gyration might be about 3.5 inches.

POI George Strom has also published some limits for the relationship between MOI and POI on page 13 of the paper referenced above. These are reproduced below:

GIVEN: Body with moments of inertia - I_{xx} , I_{yy} , I_{zz}
products of inertia - I_{xy} , I_{xz} , I_{yz}

COMPUTE:

If the moments and products of inertia represent a real body, the following four inequalities must be true.

$$A^2 \leq 1$$

$$B^2 \leq 1$$

$$C^2 \leq 1$$

$$A^2 + B^2 + C^2 - 2ABC \leq 1$$

If any of the four inequalities is not true, then rotating the moments and products to the principal axes will yield one moment of inertia greater than the sum of the other two or one moment of inertia negative.

Conclusions Considerable knowledge and skill is required for you to get accurate mass properties measurements. If you buy a good instrument, then the limit on your accuracy will be one of the seven factors discussed in this paper.

Richard Boynton is President of Space Electronics, Inc., Berlin, Connecticut, a company he founded in 1959. Space Electronics, Inc. manufactures instruments to measure moment of inertia, center of gravity, and product of inertia. Mr Boynton holds a B.E. degree in Electrical Engineering from Yale University and has completed graduate studies in Mechanical Engineering at Yale and M.I.T. He is the author of over 51 papers, including 18 papers presented at past SAWE conferences. Mr. Boynton has been a member of SAWE for 24 years and is currently President of the Boston Chapter. He has designed many of the mass properties measuring instruments manufactured by Space Electronics. Also, Mr. Boynton is the Chief Executive Officer of Mass Properties Engineering Corporation and is a professional folksinger.