

GB Series

Moment of Inertia Measurement Instruments



to the operator, acquire data from the instrument, calculate results, and print a report of results.

Construction

These instruments operate on the principle of the inverted torsion pendulum. The drawing below identifies the main components of the system.

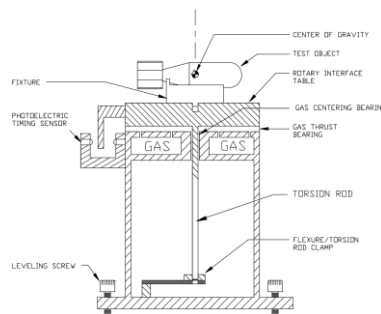

The test object is supported by a gas bearing, which presents the advantage of minimizing friction and damping of the system.

A torsion rod attached to the bearing provides a constant torsional stiffness.

A sensing device produces timing pulses which start and stop a digital period counter to determine the period of the oscillating system.

Selecting Instrument Size

There are three factors to consider in the choice of instrument size:

1. Maximum Weight of Test Part and Fixture. There is no limit on maximum moment of inertia. A practical ratio is to keep the mass of the fixture in the range of 30 to 70% of payload mass.
2. Tare Moment of Inertia, which is the inertia of the mobile assembly of the instrument itself. It affects the smallest moment of inertia that can be measured with rated accuracy.
3. Maximum Center of Gravity Height of the Test Object. Because the instrument is not infinitely stiff a very tall object would make the instrument lean. In that case a larger instrument than is strictly necessary for payload weight would be required to measure the payload.

Description

We make six types of moment of inertia instruments covering a range of prices and accuracies. The GB Series have been designed for measurement of heavy test parts. They are often used for critical tests on space and military applications. These rugged instruments are manufactured with various accuracy levels.

Five standard sizes are available for test parts weighing up to 13,000 lb. In addition to its use as a design tool, this instrument is fast enough for use in line for production quality analysis.

We offer optional interfacing and software to display instructions

General Specifications

Model	GB150AX	GB550AX	GB3300AX	GB8800AX	GB13000
Payload Weight Capacity (including test part and fixture)	150 lb	550 lb	3,300 lb	8,800 lb	13,000 lb
Maximum CG height (payload weight at CG height)	40 lb @ 24"	440 lb @ 24"	2,200 lb @ 48"	8,800 lb @ 78"	13,000 lb @ 88"
Overturning Moment	600 lb-in	800 lb-in	8,000 lb-in	44,000 lb-in	70,000 lb-in
Tare Moment of Inertia	130 lb-in ²	220 lb-in ²	1,600 lb-in ²	38,300 lb-in ²	64,000 lb-in ²
MOI Accuracy (% of reading + lb-in ²)	0.1% + 0.03	0.1% + 0.03	0.1% + 0.15	0.1% + 2.5	0.5% + 6

Calibration hardware is included with all our instruments.